

120

Industrial & Commercial
Sweepers



DULEVO

FAYAT GROUP

TIMELESS QUALITY THROUGH PASSION



If dust is your problem, the sweeper 120 is more than just a solution, but an extraordinary opportunity. Designed to work in any environment, it is a unique machine: robust, reliable and silent. Capable of picking up both the finest dust and gravel, this sweeper is perfect for all heavy industry applications, but also suitable for use in public environments and loading/unloading areas such as warehouses, docks, car parks.

Designed for the operator

The operator's space with adjustable steering wheel is designed to comfortably accommodate any height, from the tallest to the shortest, and provide a comfortable and ergonomic working environment that helps reduce back strain and fatigue throughout the entire shift. The option of a soundproofed and air-conditioned cab allows the operator to work in any harsh environment.

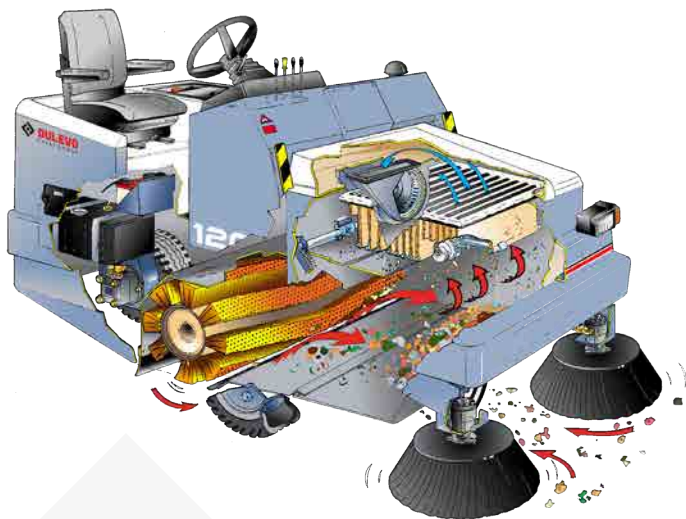

Collection system

Collection is by means of side brushes that convey the debris to the center of the machine where the central cylindrical brush throws it at high speed directly into the container. The cleaning track varies from in 47.3 to in 80.8 (mm 1.200 - mm 2.050). The dust is sucked up and retained in the container thanks to the vacuum created by a high capacity, high head suction fan.

Filter system

In addition to the high-quality filter fitted as standard, it can be equipped with a PTFE membrane filter. Membrane technology achieves the best filtration results through: better dust control, improved suction, and easier and cheaper maintenance.

Versatility

Three different engine - electric, LPG and diesel - allow the choice of the most suitable machine for each working condition. The availability of a protective overhead or cabin, possibly equipped with a heating or air conditioning system, allows the 120 to be used outdoors and in the most extreme working conditions, with the guarantee of maximum efficiency, quality and safety at all times.



Environment

Concern for the environment has always been a key driver for our company. The different drive technologies, battery or endothermic motors of the latest generation, combined with dust filtration and the possibility of sweeping without the use of water, are the milestones of the 120.



The Dulevo 120 in brief:

- 2-year warranty;
- Steel frame suitable for heavy-duty work;
- High dump;
- Water-cooled engines to cope with very hot climates and long shifts;
- Power steering as standard, for a more comfortable and pleasant ride;
- Compaction system inside the body to increase collection capacity;
- No electronics;
- Bulky waste hatch as standard;
- Tool-free replacement of central and side brush.

Technical Data		120EH	120BK	120DK
Power supply		Battery 48V	Petrol / LPG	Diesel
Sweeping width:				
- With main broom	in		47.3 (mm 1.200)	
- With Rh side brush	in		59.1 (mm 1.500)	
- With Rh + Lh side brushes	in		70.9 (mm 1.800)	
- With 3rd front brush Rh and Lh (180°)	in		80.8 (mm 2.050)	
Container volume	gal		211.4 (L. 800)	
Dump height	in		59.1 (mm 1.500)	
Cleaning performance	ft ² /h	176,464	220,580	176,464
	m ² /h	16.400	20.500	16.400
Maximum speed	Mph	5 (8 Km/h)	6,3 (10 Km/h)	5 (8 Km/h)
Length x width x height (with Cabin)	in	98.5 x 61.5 x 60.7 (92.13)		
	mm	2.500 x 1.560 x 1.540 (2.340)		

Applications* . A wide range of options and accessories, complementing its features, places the 120 at the highest level for versatility and ductility.

- Filter with PTFE membrane
- Left hand side brush
- Right hand front extendable brush unit
- Right side brush casing
- Left side brush casing
- Water sprinkling system for brushes
- Front suction hose
- Overhead roof with stroboscopic beacon
- Full cabin
- Cab pressurization system
- Rear-view mirror (DK/BK)
- Cab heating system (DK/BK)
- Cab air conditioning system (DK/BK)
- Superelastic tyres
- Pneumatic tyres with foam
- Non-marking superelastic tyres
- Adjustable steering wheel
- Rear steel bumper
- Beacon without support

- All-around rubber bumper
- Side and rear rubber bumper
- Tie down hooks
- Chassis customized painting
- Indicator of clogged engine filter
- Stainless steel waste container
- Lighting system
- Vertical muffler
- Engine air double cartridge + Vortex pre-filter
- Safety belt
- Beacon with support
- LPG system (bottle not included)



*Some pictures and equipment may show optional extras that are not available in all markets. For information ask your nearest dealer: www.dulevo.com or info@dulevo.com

Dulevo Fayat Group

Dulevo was founded in 1976 and is now part of the Fayat Group, France's largest privately-owned construction, industrial and road infrastructure group. The knowledge of cleaning technology acquired by Dulevo, based in Parma in the heart of Italy's Motor Valley, forms the basis of our state-of-the-art and reliable machines. Our motto, 'Timeless Quality through Passion', reflects our commitment to providing innovative, high quality cleaning solutions to municipalities and industry, with a focus on environmental care.



Specifications are not binding for our company and subject to change at any time without notice..



Dulevo - Fayat Cleantech Americas
725A Imperial Court, Charlotte, NC 28273
www.dulevo.com/us

Dulevo International S.p.A.
Via Giovannino Guareschi, 1
43012 Fontanellato (PR) Italy
Tel: +39-0521-827711
www.dulevo.com

QUALITY, INNOVATION AND RESPECT FOR THE ENVIRONMENT
Dulevo Certifications:

ISO 14001
ENVIRONMENTAL
SYSTEM
CERTIFICATION



ISO 9001
QUALITY
SYSTEM
CERTIFICATION



ISO 45001
SAFETY
SYSTEM
CERTIFICATION



EUnited PM TEST
COLLECTION AND
FILTRATION
DUST

