

D6

Street Sweeper



DULEVO
FAYAT GROUP

TIMELESS QUALITY THROUGH PASSION

ENVIRONMENT

Reduced environmental impact

The high technology of the Dulevo D6 provides an environmentally friendly machine.



ENVIRONMENT

Reduced environmental impact

Low sound power

Less than 100 db thanks to Load Sensing.

Low fuel consumption

Electronic transmission and high sweeping speed.

Low engine emission

The engine complies with the latest European emission regulations.



Low fine dust emissions

EN15429 certified filtration system. Possibility of fitting a filter with PTFE membrane to increase performance.

Reduced water consumption

The mechanical suction system allows the machine to work, drastically reducing water consumption.





PRODUCTIVITY

Efficiency and cost reduction

Dulevo is targeting the heavy industry market, the mining sector and at the same time public administrations with its patented mechanical-suction-filtering system that reduces cleaning costs and time.

PRODUCTIVITY

Mechanical-suction-filtering system

Savings in water consumption

The limited use of water, or lack of use, makes it possible to drastically reduce or even exclude the H₂O replenishment time required in conventional systems for PM 10 & 2.5 and dust abatement (double cost).



Saving time

Three times the sweeping speed of any other machine on the market.

No sweeping limit

Possibility of collecting light, heavy and even bulky materials.

12 months of use

12 months of useability to sweep even without using water makes it possible to also work with low outdoor temperatures.

in short:

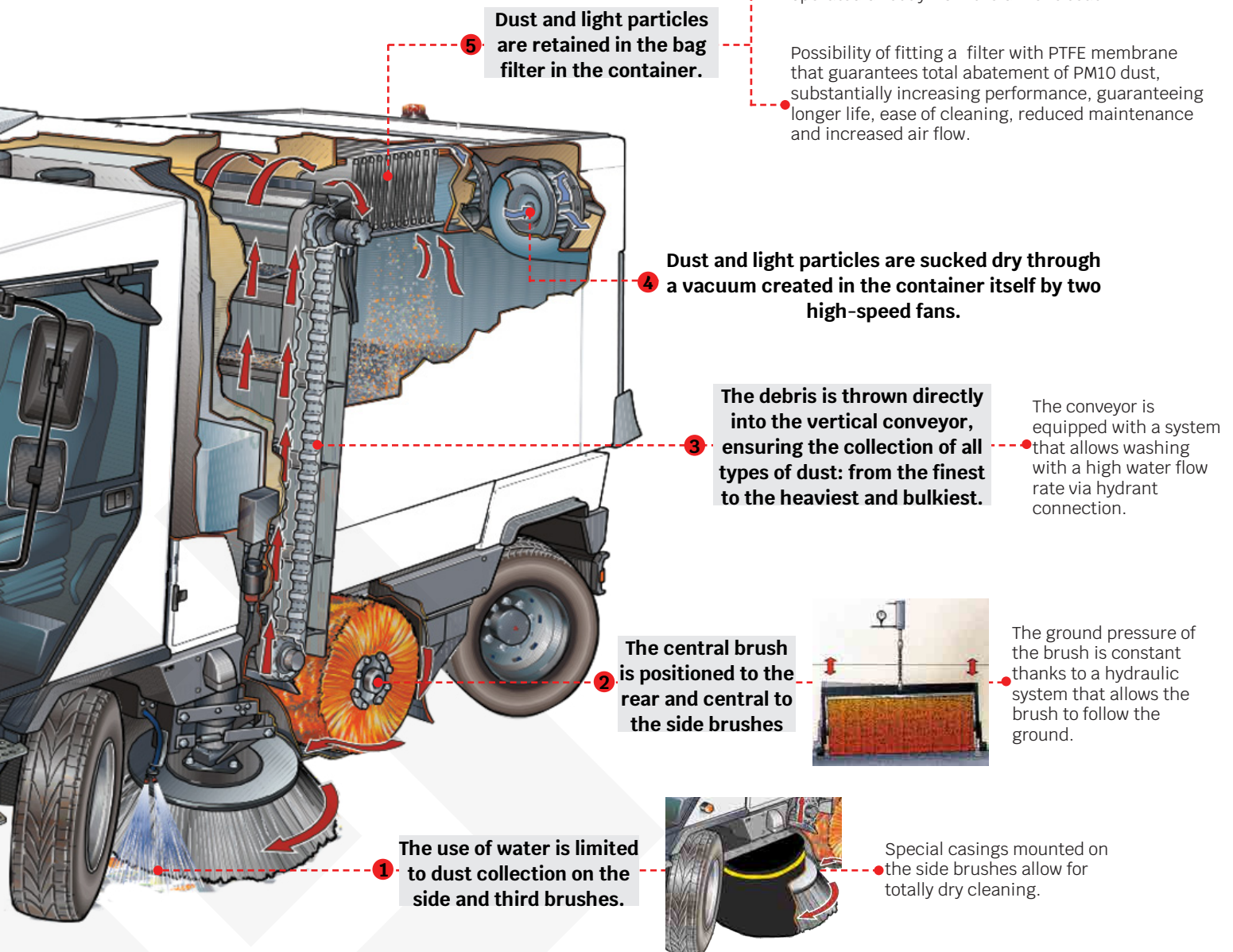

DULEVO CONNECT

Smart Thinking

Easy and intuitive use

Less time needed to train the operator, possibility to customize the operating methods of the vehicle.

Touchscreen Panel

User friendly and Easy Start functions.

On-board diagnostics

Possibility to directly access the function diagnostics and the motor status indications from the display.

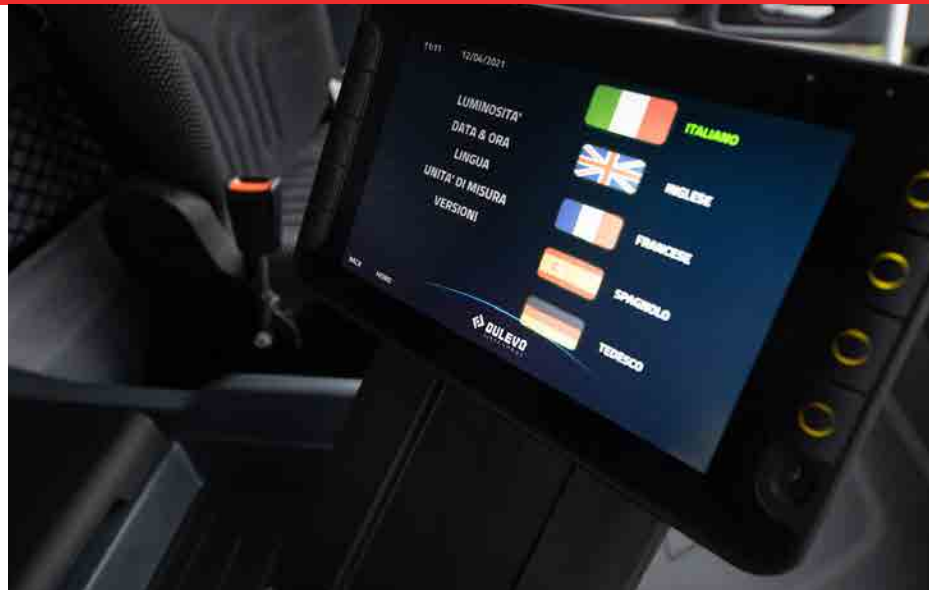

Dulevo Telematic (Tierra)

Possibility to remotely access the vehicle diagnostics and informations.

Set-up for remote connectivity 4.0 Smart City

Two-way interface system.

Can Bus

In/Out communication system of the sweeping functions and motor on CAN-BUS protocol.



QUALITY OF LIFE ON BOARD

Designed for the operator's wellbeing

A comfortable and pleasant sweeper
to use even after many hours of
work.



QUALITY OF LIFE ON BOARD

Designed for People



Greater cabin space

Tunnel removal and the possibility of having up to 3 cabin seats.

Less noise in the cab

Less than 70 db thanks to the new soundproofing concept.

Filtering and pressurization system

System designed to meet the high standards and regulations of the agriculture sector.

Ergonomic cabin layout

- Layout of controls and display of ergonomic and adjustable functions according to the operator's needs.
- 10" Interactive display for sweeping function.
- 4.3" display for engine and road circulation functions.
- Armrest with multifunction
- Joystick.

Simplified daily maintenance

- Hydraulic opening of the Box Door.
- Conveyor washing with hydrant connection.
- Water system draining system.
- 50% faster central brush replacement system.



VERSATILITY

Adaptable to different sweeping needs

Different ways of using the sweeper based on the environments or type of materials to be collected.

**A.S.T.**

- Possibility of selecting different work programs: STD, ECO, Boost and Leaves.
- Possibility of storing customized work programs by operator, environment or work mode.

Adjustable Working Speed (A.W.S.)

Possibility of adjusting the maximum working speed.

Adaptive sweeping width

Ability of the side brushes to open and close according to the steering angle.

Memory

Possibility of putting the functions in Stand-by and resume work with the same configuration.

4 and 2 steering wheel system

- Possibility of selecting the most comfortable transfer mode.
- 4 steering wheels for maximum maneuverability.
- 2 steering wheels for greater comfort and driving precision/ simplicity.
- Automatic alignment of the wheels.



Combi equipment

The Combi equipment combines sweeping, washing and sanitizing functions. The machine, with one operator and directly from the from the driver's seat, can sweep and wash/sanitize at the same time and in a single operating step.

The high-pressure lance with facilitating arm allows a second operator to wash and sanitize pavements even in the presence of parked cars.

- Water sprinkling system for side brushes with pneumatic emptying system
- High pressure washing system with gun and reel 11 mt
- Additional water tank
- High pressure rear sprinkling bar
- Spray turning arm gun



OTHER SUGGESTED CONFIGURATIONS*

Our experience has led us to develop configurations that suit different cleaning areas, types of dirt to be cleaned, and general customer needs.



Municipal Equipment

Suggested configuration for municipal and urban centers

- Hydraulic dumping up to 2400 mm
- 180° Right hand/Left hand front extendable brush unit with mirror
- Water sprinkling system for side brushes
- Water sprinkling extension for right hand front extendable brush unit
- Suction system without hose
- Ø 150 mm hose - Length 5 mt
- Centralized manual greasing system without pump
- Filter with PTFE membrane
- Radio with USB and Bluetooth



Airport Equipment

Suggested configuration for airports

- Hydraulic dumping up to 2400 mm
- 180° Right hand/Left hand front extendable brush unit with mirror
- Rubber skid for central brush
- Water sprinkling system for side brushes
- Water sprinkling extension for right hand front extendable brush unit
- High pressure washing system with gun and reel 11 mt
- Suction system without hose
- Ø 150 mm hose - Length 5 mt
- Centralized manual greasing system without pump
- Rear magnetic bar
- Customized painting (no chassis)
- Reflecting stripes
- PPL side brushes



Cement Equipment

Suggested configuration for cement, ceramic sector or where water cannot be used

- Side brushes casings (sweeping width reduced to 2250 mm)
- Suction system without hose
- Hose Ø 150 mm hose - Length 5 mt
- Additional Vortex pre-filter for endothermic engine
- Centralized manual greasing system without pump
- Filter with PTFE membrane



Heavy industry Equipment

Suggested configuration for heavy industry or the metallurgical sector

- Hydraulic dumping up to 2400 mm
- Water sprinkling system for side brushes
- Suction system without hose Ø 150 mm hose - Length 5 mt
- Additional Vortex pre-filter for endothermic engine
- Centralized manual greasing system without pump
- Pneumatic tyres with foam
- Filter with PTFE membrane

*Some pictures and equipment may show optional extras that are not available in all markets. For information ask your nearest dealer: www.dulevo.com or info@dulevo.com

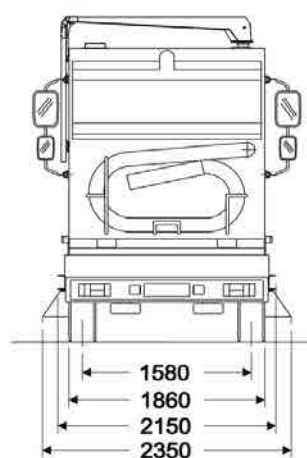
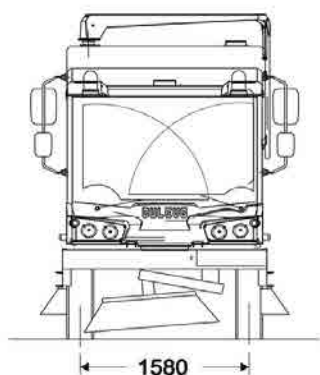
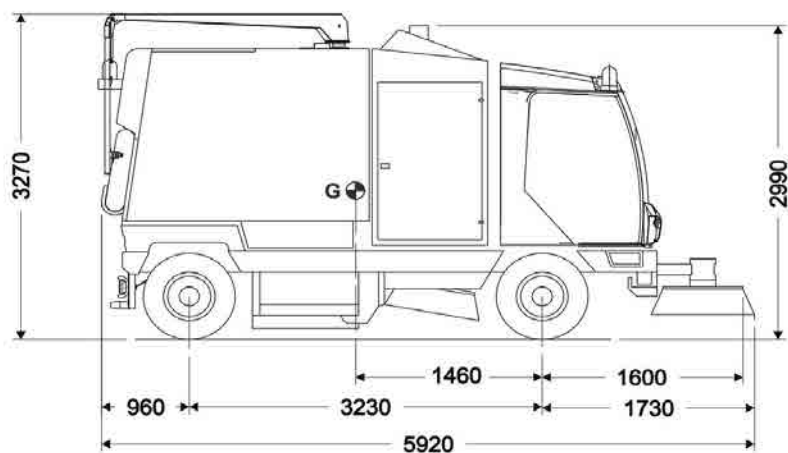

Technical Data		D6
Sweeping width:		
- With main broom	mm	1.300
- With main broom and right and left brush	mm	2.800
- With main broom, side brushes and third brush	mm	3.600
Gross hopper volume	m ³	6,2
Maximum dumping height (Opt.)	mm	1.150 (2.400)
Cabin seats (Opt.)	n°	2 (3)
Cleaning performance	m ² /h	108.000
Maximum speed	Km/h	25 - 32 - 40 - 50
Steering diameter Kerb to Kerb	mm	9.675
PM10 & PM2,5 Filtration EN 15429-3		EUnited 4 STAR
Engine brand		FPT industrial (Iveco)
Engine approval		EURO 6E / EURO 6C
Power supply		Diesel

Dulevo Fayat Group

Dulevo was founded in 1976 and is now part of the Fayat Group, France's largest privately-owned construction, industrial and road infrastructure group. The knowledge of cleaning technology acquired by Dulevo, based in Parma in the heart of Italy's Motor Valley, forms the basis of our state-of-the-art and reliable machines. Our motto, 'Timeless Quality through Passion', reflects our commitment to providing innovative, high quality cleaning solutions to municipalities and industry, with a focus on environmental care.



Specifications are not binding for our company and subject to change at any time without notice..



DULEVO
FAYAT GROUP

Dulevo International S.p.A.
Via Giovannino Guareschi, 1
43012 Fontanellato (PR) Italia
Tel: +39-0521-827711
Fax: +39-0521-827795
www.dulevo.com

QUALITY, INNOVATION AND RESPECT FOR THE ENVIRONMENT

Dulevo Certifications:

ISO 14001
ENVIRONMENTAL
SYSTEM
CERTIFICATION



ISO 9001
QUALITY
SYSTEM
CERTIFICATION



ISO 45001
SAFETY
SYSTEM
CERTIFICATION



EUnited PM TEST
COLLECTION AND
FILTRATION
DUST

