

D.zero²

Street Sweeper
100% electric



DULEVO
FAYAT GROUP

TIMELESS QUALITY THROUGH PASSION



The evolution of all-electric sweeping

The third-generation D.Zero², with its remarkable manoeuvrability and numerous innovative technologies, is the ultimate expression of all-electric sweeping.



Electric motors

More advanced, higher-performance and more energy-efficient motors.

Faster charging

AC charging on the new D.Zero² is faster thanks to the new On-Board charger, reducing charging time.

Charging sockets

Equipped with COMBO CCS Type 2 and Type 1 socket to cover the needs of major markets.

Batteries

The new batteries with the latest Lithium-Iron-Phosphate cells not only reduce the weight of the machines but also offer a higher standard warranty coverage.



Charging points

The Combo version allows AC charging (charging points or Wall Box) and DC charging (external charger).

Reduced environmental impact

High-tech, electric motors for machines that respect people and the environment around them.

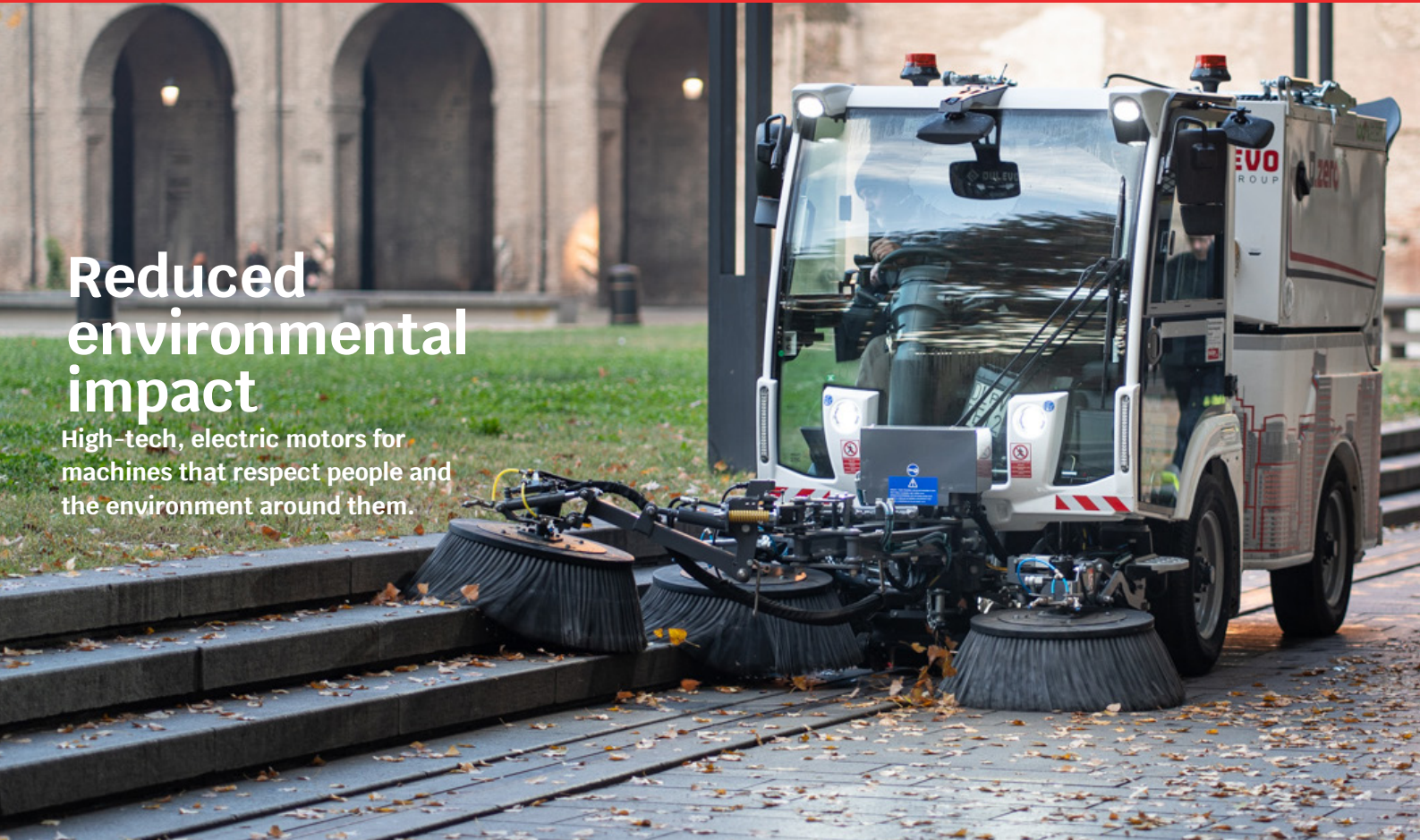

Low sound power

With 80% of the most common sweeping activities being carried out in ECO mode, the noise emissions are significantly reduced to be able to work at night for street cleaning without disturbing the peace.

Reduced water consumption

The wastewater recycling system fed back into the suction inlet significantly reduces the need for it.



Dust control

A steel filter and a large water tank guarantee total dust control.

Electric street sweeper

The electric street sweeper has zero CO₂ emissions and zero harmful gases re-emitted into the environment.



Designed for people

Driving and working comfort is more than just a luxury when driving a sweeper. The new cab has been designed to be comfortable and pleasant to use even after many hours of work.



Relaxed driving

The ergonomic cab and a wide range of seat and steering column settings mean that the driving position can be adapted to all body builds.

360° view

The large windscreen, glazed side doors, panoramic and wide-angle mirrors, rear panels, rear window for the intake nozzle and rear cameras provide an unsurpassed all-round view.

Multifunctional joystick.

The operator has full control of the sweeping functions. With the adoption of this innovative joystick, the concepts of ergonomics and versatility have been amplified.

Control panel

Ergonomic and adjustable control layout and function display according to the operator's needs.



Smart Thinking

Diagnostics and vehicle information are remotely accessible. Monitoring the position of the sweeper, how it is used and any stoppages or breakdowns. Automatic service and maintenance planning.

CAN-BUS

In/Out communication system of sweeping and motor functions on CAN-BUS protocol.

Easy stop

All functions are deactivated, the suction mouth is raised and the brushes are lifted returning to the position (within the machine shape) of minimum clearance to move into transfer mode.

A.S.T.

Different work programs can be selected:

- ECO;
- STANDARD;
- HEAVY;
- BOOST (for limited time of use).

Easy Start

At the push of a button, the sweeper is ready for work. For maximum efficiency, the machine is also equipped with an automatic stop system in case the sweeper is in a non-working position for a certain period of inactivity.

Machine operator interface

Diagnostics and vehicle information are remotely accessible. Monitoring the position of the sweeper, how it is used and any stoppages or breakdowns. Automatic service and maintenance planning.



The third-generation D.Zero² in brief:

Regulations EU 17106 Compliant. The machine was designed taking into account the new requirements demanded and defined for the safety of road surface cleaning machines.

New cab

The operator's comfort directly impacts productivity.

Container

The container opening is offered in two different solutions: unloading mode and possible coupling with compactors.

Fast Charge

The new version can be equipped with a new, more powerful and intelligent On-Board charger in addition to the two types of charging systems with external chargers.

Suction mouth

The inlet and its flap opening system are covered by a patent filed by Dulevo.

Batteries

The new lithium battery pack has been developed using the latest generation of cells available on the market.

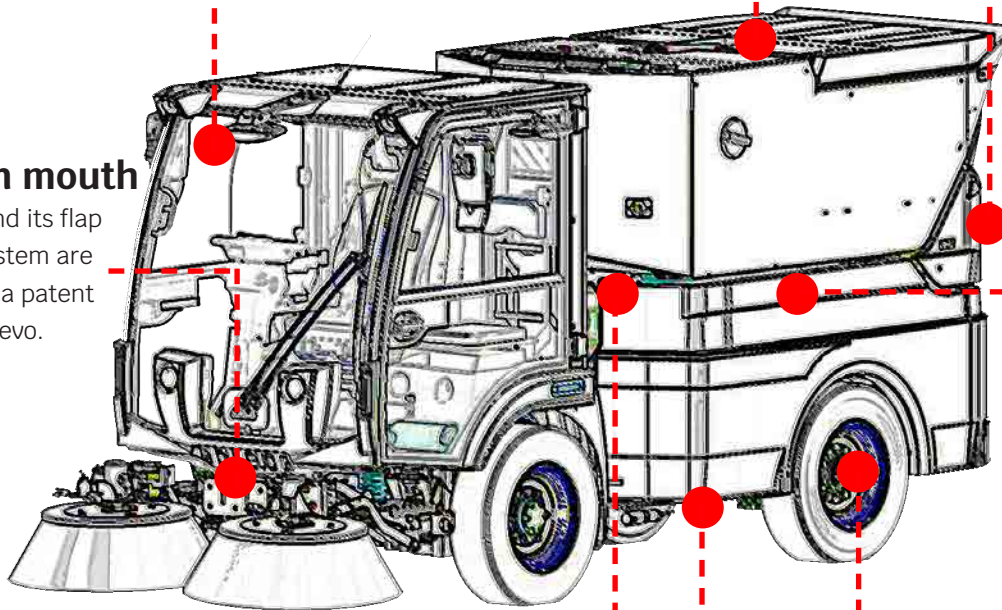

Suction hose

With a diameter of 200 mm, it is installed in an outward, easy-to-inspect position without bends. For maximum performance, the coupling is through a spring-compensated flange.

Speed

The maximum speed - 40 km/h - of the vehicle is higher, reducing transfer times and increasing productivity.

Braking system

Greater speed requires greater safety and braking power. The new D.Zero² has an improved service and parking brake system.



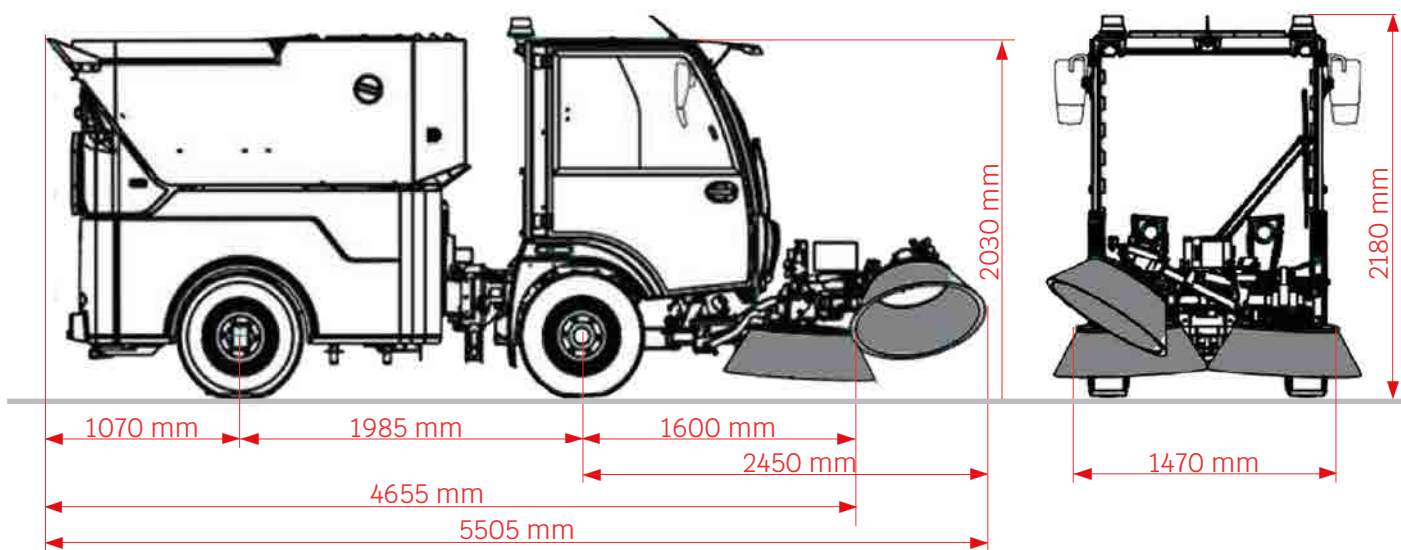

Technical Data		D.zero ²
Variable weeping width:		
- Minimum	mm	1.750
- Maximum	mm	3.200
- With 3rd front brush	mm	3.400
Gross hopper volume	m ³	2
Hydraulic drumming up	mm	1.450
Cabin seats	n°	2
Cleaning performance	m ² /h	42.000
Maximum speed	Km/h	25 - 40
Steering radius - Kerb to Kerb	mm	3.750
PM10 & PM2,5 Filtration EN 15429-3		EUNITED 4 Star
Power supply Battery	KW/h	75

Applications*. A wide range of options and accessories, complementing its features, places the D.zero² at the highest level for versatility and ductility.

- Third brush
- Side brushes inclination adjustment from the cabin
- HP washing system with gun and automatic reel
- Spare tire (not on board)
- Hydraulic Jack
- Reflecting stripes
- Wax film for sea freight
- Suction unit with hose Ø 100 mm – Length 3 mt
- “External charger with Combo CCS Plug
In: 400V / 27A - Out: 96V / 150A”
- “Fast Charger with Combo CCS Plug
In: 400V / 44A - Out: 96V / 250A”



*Some pictures and equipment may show options that are not available in all markets. For information contact your nearest dealer: www.dulevo.com or info@dulevo.com

Dulevo Fayat Group

Dulevo was founded in 1976 and is now part of the Fayat Group, France's largest privately-owned construction, industrial and road infrastructure group. The knowledge of cleaning technology acquired by Dulevo, based in Parma in the heart of Italy's Motor Valley, forms the basis of our state-of-the-art and reliable machines. Our motto, 'Timeless Quality through Passion', reflects our commitment to providing innovative, high quality cleaning solutions to municipalities and industry, with a focus on environmental care.



Specifications are not binding for our company and subject to change at any time without notice



DULEVO

FAYAT GROUP

Dulevo International S.p.A.
Via Giovannino Guareschi, 1
43012 Fontanellato (PR) Italia
Tel: +39-0521-827711
Fax: +39-0521-827795
www.dulevo.com

QUALITY, INNOVATION AND RESPECT FOR THE ENVIRONMENT

Dulevo Certifications:

ISO 14001
ENVIRONMENTAL
SYSTEM
CERTIFICATION



ISO 9001
QUALITY
SYSTEM
CERTIFICATION



ISO 45001
SAFETY
SYSTEM
CERTIFICATION



EUnited PM TEST
COLLECTION AND
FILTRATION
DUST

